



AP-05 RFID Reader

The AcuProx AP-05 is an encapsulated small and high performance reader due to its design it can be applied in various environments.

Purchase Code: 500.462

• Features

The AP-05 is a stylish and reliable reader proximity to the casing smooth finish that fits perfectly into multiple environments. For cutting-edge designs, the AP-05 meets with excellent performance and appearance and logo customizable and configurable color LED and buzzer sound. It has wide applications in the area of access control with their communication interfaces Serial TTL RS-232, Wiegand 26 bit, Magstripe ABA TK-2 and RS-485 (optional), with parameters set via software. The AP-05 works in a range of ideal voltage for the most common applications in the market.

• Characteristics

- 6 selectable LED colors on standby and reading;
- Most common communication interfaces in the market;
- Quality finish;<
- Easy installation, reducing cabling work;
- Wide operating voltage of 7,5 to 12V DC;
- 2 digital inputs and 2 outputs controlled by RS232 TTL.

• Dimensions [mm]

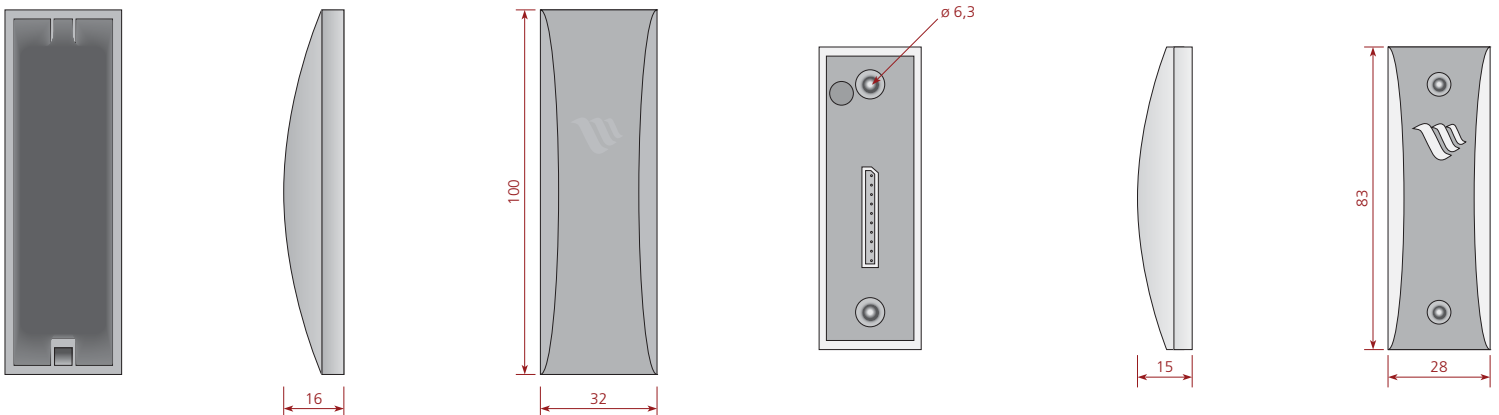

• Technical Specifications

Power	7,5 to 12 VDC
Consumption	75 mA @ 12 VDC
Communication Interfaces	Wiegand 26 bits, Magstripe (ABA TK2), Serial TTL RS-232 and Serial RS-485 (optional)
Reading Range*	Up to 10,5 cm, with an AcuProx ISO Card Up to 10 cm, with an AcuProx Card Up to 15 cm, with an AcuProx Card HP
Frequency of operation	LF - 125 kHz
Modulation	ASK
Protocol	ISO 11784/85
Transponder	Only reading cards and tags AcuProx
Dimensions	32 x 100 x 16 mm
Weight	95 g
Operating Temperature	-10° to 60°C
Humidity	10% to 90% (non-condensing)
Protection degree	Not apply
Installation	External surfaces or embedded in equipment.

* Considering power regulated and stabilized 12V DC installation electromagnetic noise-free environment and without the presence of metal surfaces near the reader source.